

Caliper overhaul instructions

Thank you for purchasing this Moto-Master performance product. Please read these instructions carefully before attempting installation. *

Step 1

Remove banjo bolt and brake line. Remove brake pad pin R-clip (1), brake pad pin (2) and brake pads (3). Measure the thickness of the friction material. When the thickness is under 1 mm, replace brake pads.

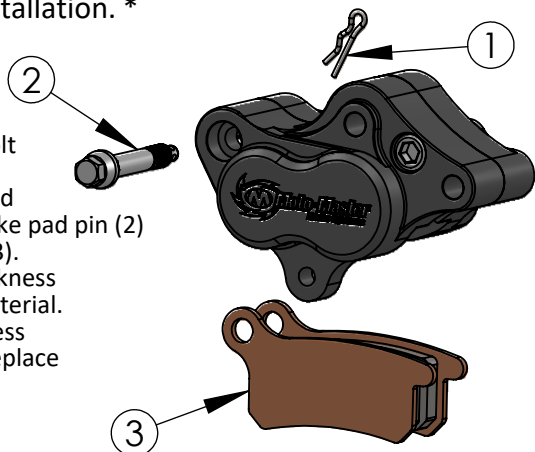

Step 2

Remove caliper bolt (4) and separate the caliper bodies (5+6). Remove caliper body seal ring (7).

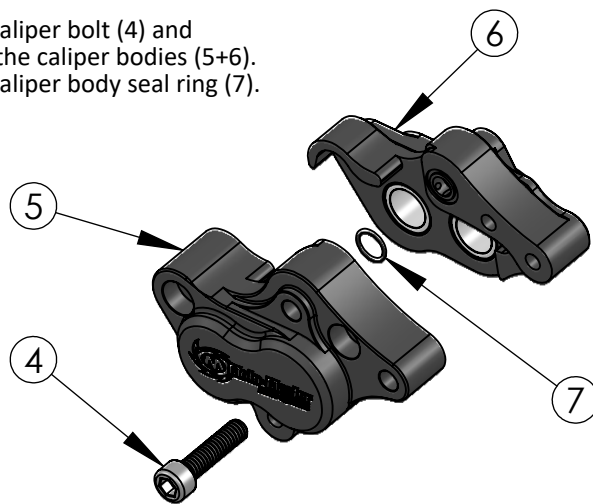

Step 3

Remove old caliper pistons (8) and piston seal rings (9). Clean both caliper bodies (5+6) with a non-aggressive chemical (no basic soda or brake cleaner). Rinse and dry thoroughly. No water is allowed to remain!

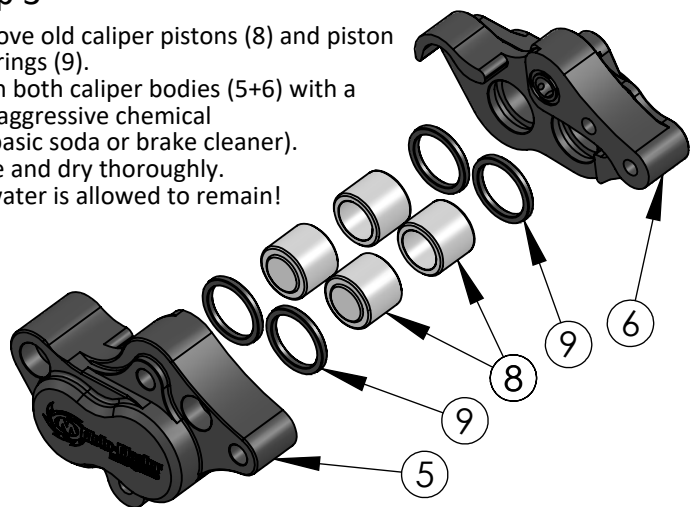

Step 4

Apply special supplied grease on the new piston seal rings (9) and the outside of the new pistons (8). Insert the new piston seal rings (9) followed by the new pistons (8).

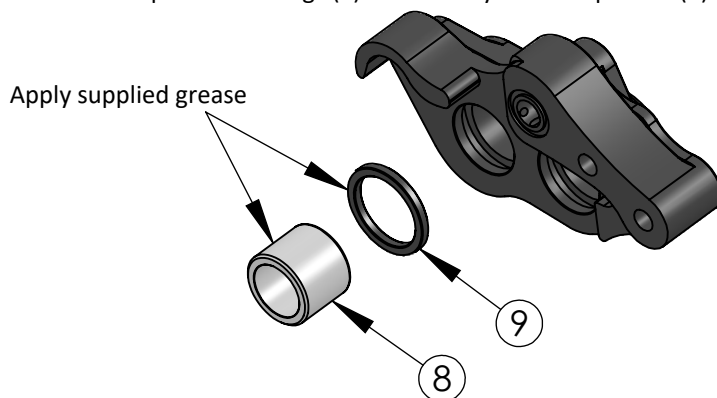

Step 5

Reassemble caliper by bolting the bodies (5+6) together (10 Nm + drop Loctite 243) with new caliper body seal ring (7) positioned correctly in between.

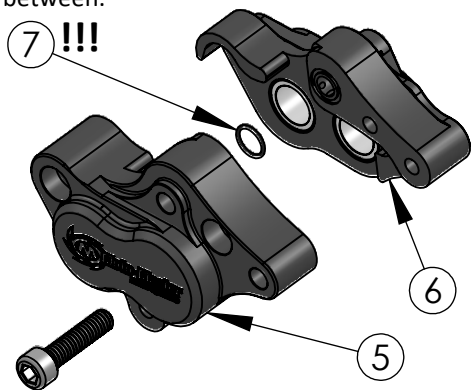

Step 6

Reinstall the brake pads (3) and brake pad pin (5 Nm) (2). Mount the R-clip (1) on the brake pad pin (2).

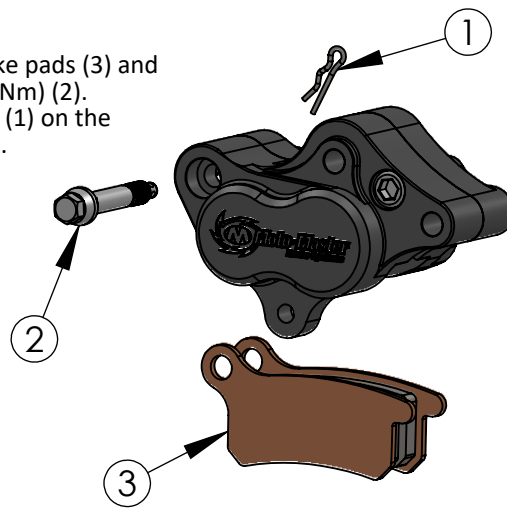

Step 7

Connect brake line and master cylinder. Refill the system with new DOT 4 or DOT 5.1 brake fluid from a sealed container and bleed the system thoroughly so NO air can remain in the brake system.

Contents of overhaul kit 213015:

- 4x Caliper piston
- 4x Piston seal ring
- 1x Caliper body seal ring

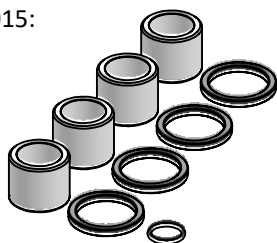

*Consult a certified dealer of professional mechanic if you are not fully qualified in motorcycle maintenance. Moto-Master cannot be held responsible for any damage or injury caused by incorrect product mounting, disregarding specifications and these instructions, or product mounting by an unqualified third party.



For more info, check:

WWW.MOTO-MASTER.COM